 cUL  
 E301099

# SÉRIE 1600

## FEUILLE D'INSTALLATION

### 1600 SERIES

#### INSTALLATION SHEET

Safe, Fast and Easy to install with the ELED POWER  
 Installation simple et rapide avec le système de connexion



### 1. Installation

- Appuyer et coller le ruban DEL dans la barre profilée (suivre les guides 10 mm ou 14 mm).

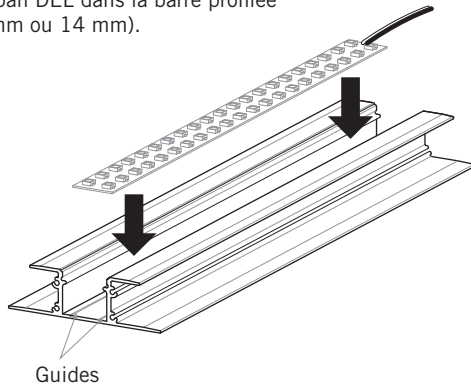

- Mettre la lentille en place.

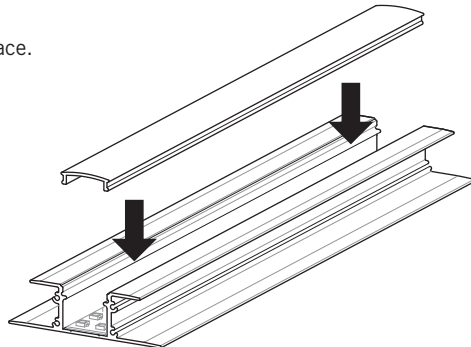

### 1. Installation

- Press and glue the LED Strip Tape into the profiled bar (follow 10 mm or 14 mm guides).

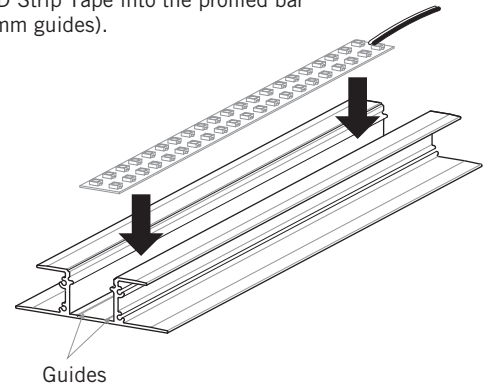

- Clip the lens into place.

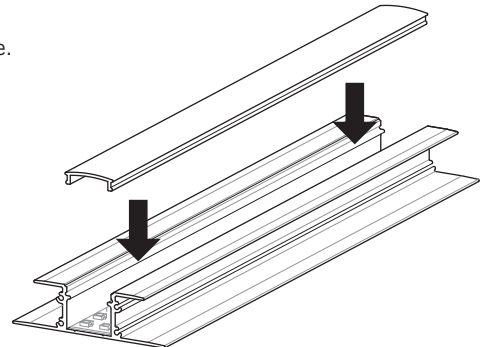

## 1. Installation

3. Installer la barre profilée entre 2 feuilles de placoplâtre de 1/2 po. (13mm). S'assurer le placoplâtre soit bien fixé par les rebords du luminaire.

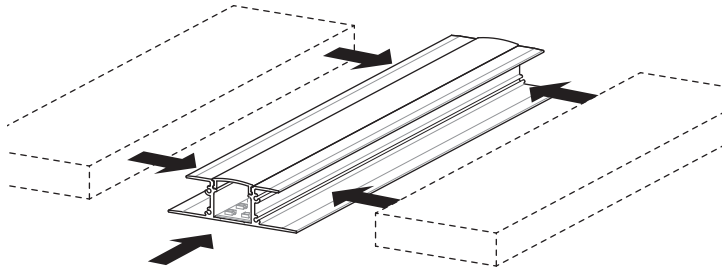

4. Installer les embouts en les vissant en place.

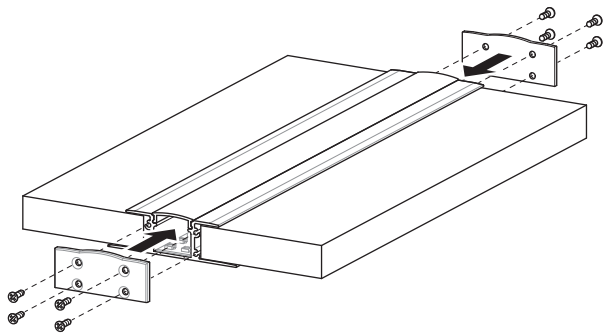

## 1. Installation

3. Install the fixture between two sheets of 1/2" drywall. Make sure drywall sheets are well secured under the fixture's edges.

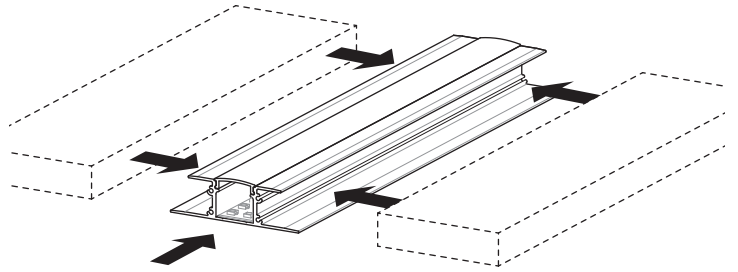

4. Install the endcaps by screwing them in place.

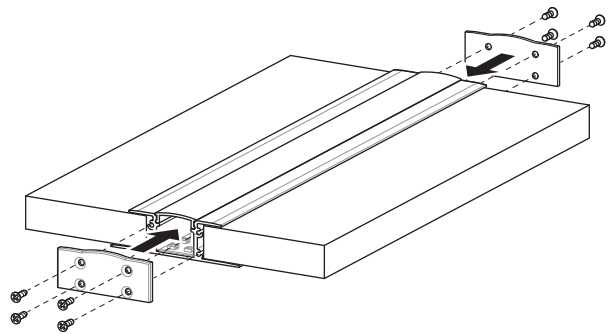

### Mise en garde

1. Utiliser seulement des composantes Certifiées Classe 2 n'excédant pas 30VCC ou 15VAC lors d'une installation dans un endroit mouillé ou 60VCC ou 42.4V ca maximum lors d'une installation dans un endroit sec ou humide.
2. Ne pas dépasser 5 ampères pour respecter les normes classe 2.

CLASSE  
2

100W  
MAX

4 AMP MAX  
↓ 24V

5 AMP MAX  
↓ 12V



### Warning

1. Use only Class 2 rated components not exceeding 30VDC or 15VAC when installing the outline lighting in wet locations or 60VDC or 42.4V peak ac when installing the outline lighting in a dry or damp location.
2. Do not go over 5 amps to match class 2 requirements.

CLASS  
2

100W  
MAX

4 AMP MAX  
↓ 24V

5 AMP MAX  
↓ 12V